

# **Proposal on the scope, content and format of Authorization of the use of ITMOs under Article 6.2**

October 2<sup>nd</sup> 2024 @ Intersessional WS  
IINO Satoru (Mr.)  
Ministry of the Environment, Japan

# Index

- 1. Process/sequence of authorization**
- 2. A copy of the authorization attached with Initial Report**
- 3. Authorization table in AEF**
- 4. Summary**

# Areas for discussion in SB60 draft text (12/6/2024)

## A) **Process and timing of authorization**

Single or sequential process vs separate processes / clarification of timing of first transfer in the authorization process

## B) **Content of authorization**

Mandatory information and voluntary information to be included (for ITMOs and cooperative approach)

## C) **Format of authorization**

Mandatory or voluntary or no standardized form

## D) **Change to authorization**

Whether changes be allowed, if so, under what conditions

## E) **Transparency of information about authorization**

How to ensure transparency on authorization

# **Process/sequence of authorization**

# Authorizations of the use of ITMOs

How to enhance environmental integrity and transparency of **“Authorizations of the use of ITMOs from each cooperative approach(SBSTA60 para8)”**

## 1. Copy of authorization attached with Initial Report

- **Voluntary standardized form** could help Parties submitting more information related to **how Parties implement authorization.**

## 2. Authorization table in AEF

- **Adoption of AEF with authorization table** help Parties submitting more detailed information on **authorization of use of ITMOS towards NDC or OIMP.**

# Initial Report

# Technical Expert Review

# Updated Initial Report

① with a copy of the authorization voluntary standardized form

- Description of approach
- Duration
- Expected mitigation
- Participating Parties and authorized entities



② with authorization table

no later than 15 April

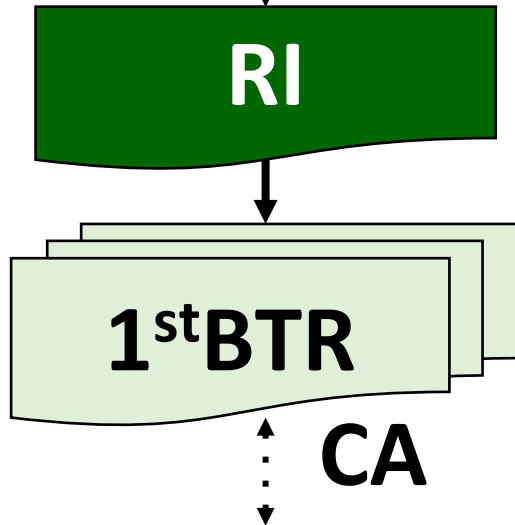

no later than 15 April

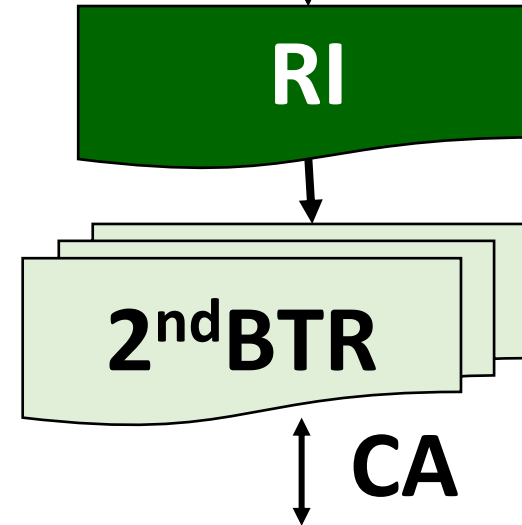

**A copy of the authorization  
attached with Initial Report**

# Key elements of voluntary standardized form

- Focus on information that constitutes ITMOs
- Avoid duplication with IR, AI, and RI
- Alignment with the table of authorization in AEF

1. Name and parameters of the cooperative approach
2. Name of authorized entities
3. Participating Party or Parties
4. Date of authorization
5. Definition of first transfer by the authorizing Party
6. Expected mitigation metrics and units of measurement
7. Vintages
8. Arrangements for authorizing entities
9. Other relevant information

## ***Decision 2/CMA.3, annex para18 (g)***

*The initial report shall contain comprehensive information to:*

*(g) Provide, for each cooperative approach, a copy of the authorization by the participating Party, a description of the approach, its duration, the expected mitigation for each year of its duration, and the participating Parties involved and authorized entities;*



## Comparison with elements listed in para 8&9 SBSTA60 (12<sup>th</sup> Jun, 2024)

- Unique identifier of the cooperative approach
- Name of Party or Parties
- Date of authorization
- Definition of 'first transfer'
- Arrangements for authorizing Parties and entities
- Terms and conditions pertaining to changes to the authorization
- Arrangements for authorizing entities under the cooperative approach
- Reversals and leakage
- Type of carbon market instrument
- Sectors, vintages, activities, duration
- Metrics and units of measurement
- Tracking arrangements
- Adaptation contribution & OMGE
- Corresponding adjustments
- Environmental integrity

# Comparison with elements listed in draft decision -/CMA.5 agenda item 14(a)

10. Encourages participating Parties to include, at their discretion, the following elements in the authorization(s), as appropriate, of each cooperative approach, as per decision 2/CMA.3, annex, paragraph 18(g):

(a) Unique identifier of the cooperative approach, as obtained from the CARP, where available;

**(b) Name and parameters of the cooperative approach;**

**(c) Participating Party or Parties;**

(d) Registry or registries involved in tracking internationally transferred mitigation outcomes from the cooperative approach;

(e) Duration of the cooperative approach;

**(f) Date of authorization;**

(g) Duration of authorization;

**(h) Definition of first transfer by the authorizing Party for the cooperative approach (in accordance with decision 2/CMA.3, annex, para. 2(b));**

(i) The procedures and standards applied in the implementation of the cooperative approach;

**(j) Metrics and units of measurement;**

(k) Sectors;

**(l) Vintages;**

(m) Activity types;

(n) Contribution of resources for adaptation;

(o) Contribution to overall mitigation in global emissions;

**(p) Arrangements for authorizing entities;**

(i) Authorized entities;

**(q) Other information relevant to the authorization and cooperative approach, pursuant to decision 2/CMA.3;**

# Authorization table in AEF

## ② Authorization of ITMOs

**The use of ITMOs** to achieve NDCs under this Agreement shall be voluntary and **authorized** by participating Parties. **(PA 6.3)**

Each participating Party shall...submit... (a) **annual information** on **authorization of ITMOs** for use towards achievement of NDCs, **authorization of ITMOs** for use towards OIMPs... **(Decision 2/CMA3, annex, chapter IV, para. 20 (a))**

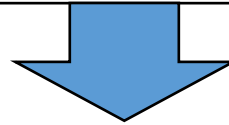

### Annual Information (Agreed Electronic Format)

#### Table 1: Submission

- Party, Status, etc.

#### Table 3: Actions

- ITMOs, transfer, use, etc.

#### Table 4: Holdings

- ITMOs details

#### **Table 2: Authorizations**

- Detailed information on authorizations for NDC and OIMP
- Terms and conditions

Ref: Article 6.2 SBSTA 60 Draft text  
(Version 12<sup>th</sup> Jun, 2024)

## AEF Table 2: Authorizations

- Focus on information that constitutes ITMOs
- Avoid duplication with IR, AI, and RI
- Alignment with the voluntary standardized form for Initial Report

- Authorization ID
- Date of authorization
- Cooperative approach ID
- Version of the authorization
- [First transferring [participating] Party ID]
- Metric and quantity
- Sector(s)
- Activity type(s)
- Purpose for authorization
- [Authorized Part(ies) ID]
- [Authorized entit(ies) ID]
- OIMP authorized by the Party
- Authorized [use] timeframe
- [Authorization][Authorized] terms and conditions
- Authorization documentation
- First transfer definition for OIMP

# Summary

# Summary

1. Process of authorization is to be national prerogative.
2. Need to enhance environmental integrity and transparency
3. Effective reporting
  - ✓ Develop the voluntary standardized form
  - ✓ Integrating an authorization table in the Agreed Electronic Format .

\*content should focus on information related to authorization of ITMOs.

# Reference



# Summary of guidance on cooperative approaches under Article 6.2

- Some Parties choose to pursue **voluntary cooperation in the implementation of their NDCs to allow for higher ambition** in their mitigation and adaptation actions and **to promote sustainable development and environmental integrity.**(Art6.1)
- Parties shall, where engaging on a voluntary basis in **cooperative approaches that involve the use of ITMOs towards NDCs,** promote sustainable development and **ensure environmental integrity and transparency.** (Art6.2)
- **The use of ITMOs to achieve NDCs** .... shall be voluntary and **authorized by participating Parties.** (Art 6.3)

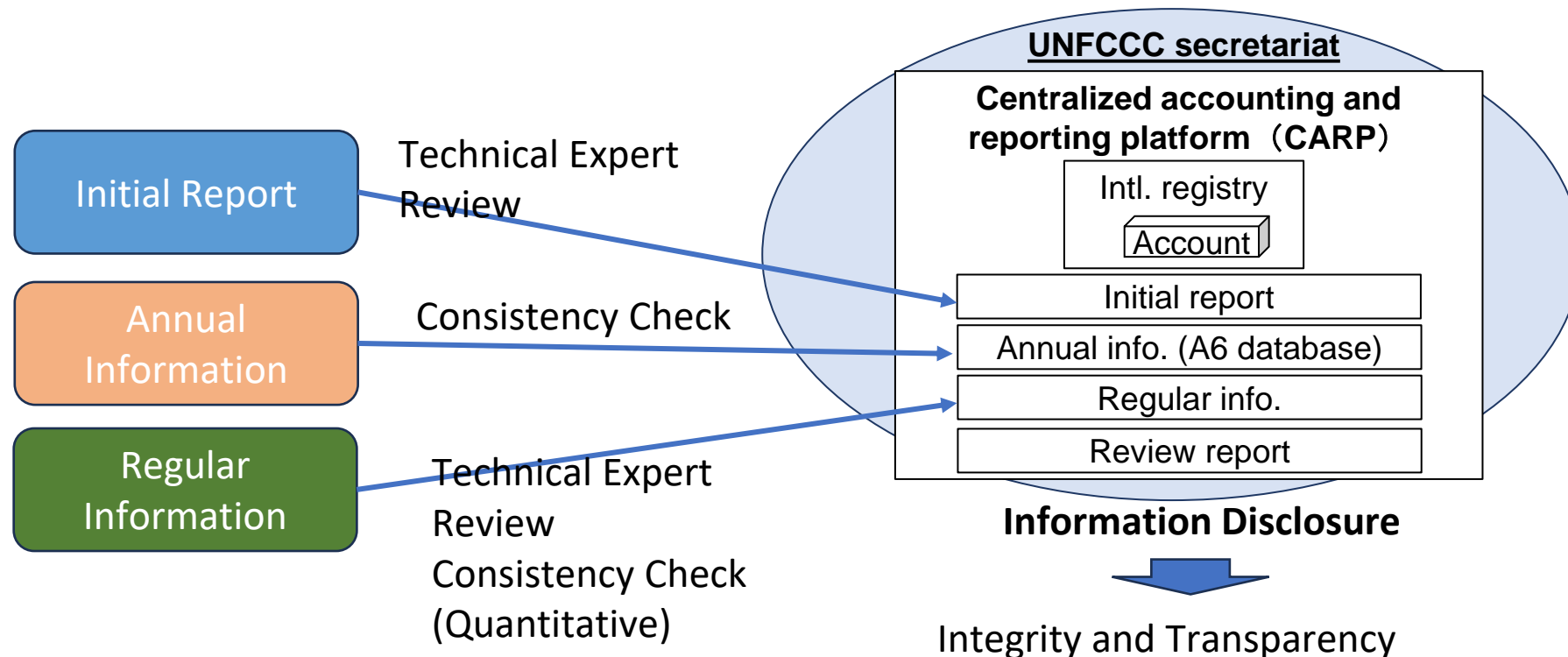

# Reporting schedule

- To ensure transparency, various steps of reporting and review are required in line with Paris Agreement Cycle.

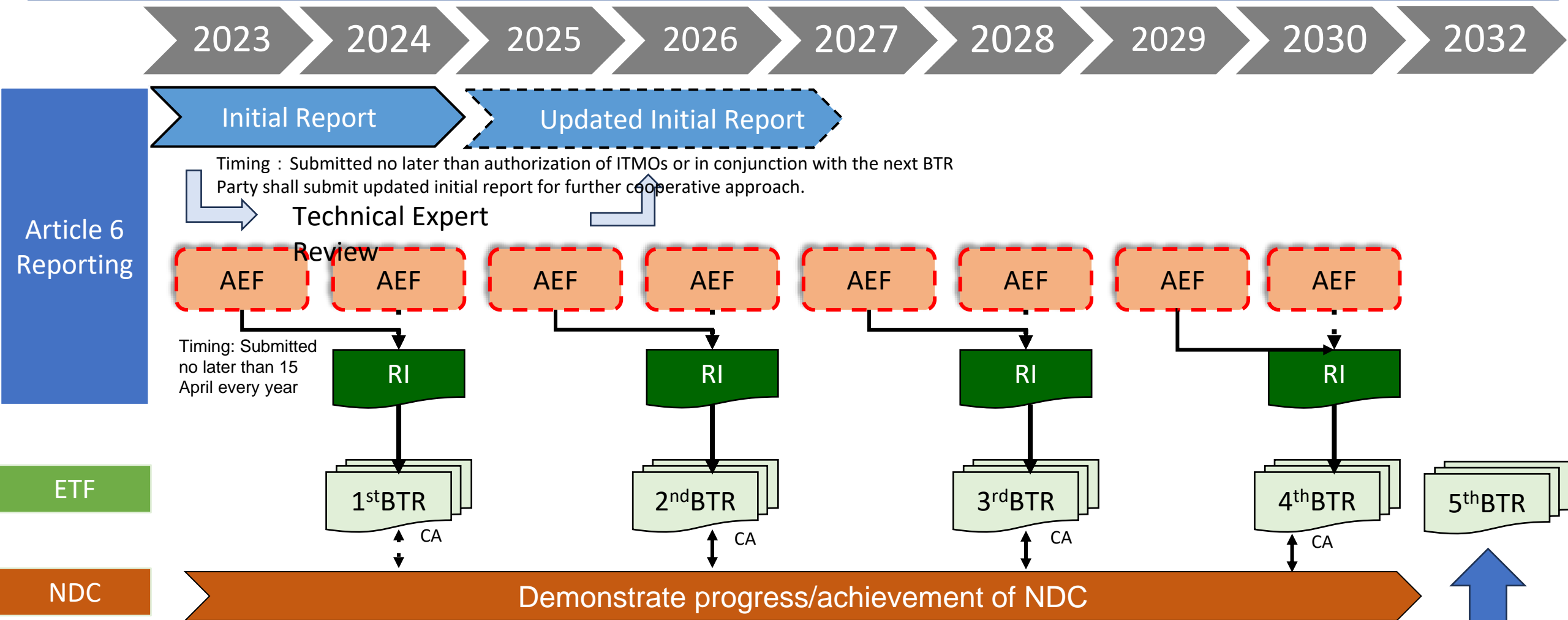

AEF: Agreed Electronic Format  
 RI: Regular Information  
 BTR: Biennial Transparency Report  
 ETF: Enhanced Transparency Framework  
 CA: Corresponding Adjustment

Use of ITMOs towards the achievement of NDCs

## **Mandate (6/CMA.4, para. 17 (b))**

Requests SBSTA to develop recommendations on the process of authorization ..., notably the scope of changes to authorization of ITMOs towards use(s), and the process for managing them and for authorization of entities and cooperative approaches with a view to ensuring transparency and consistency;

# Key points at CMA 5 in 2023

## Areas where divergent views remain

- ① Elements in the authorization / content of authorization
- ② Timing of authorization and additional processes
- ③ Identification of specific cases where changes to authorization may affect ITMOs already first transferred

## Proposal in 4<sup>th</sup> iteration (12/12/2023)

- ① Authorization may be done in a single or as a sequential process
- ② Authorization form may be developed for use on a voluntary basis
- ③ Changes to authorization should not affect ITMOs already first transferred (while noting some exceptions)

## Process (SB60 draft text (12/6/2024), para4-6 process)

### Option 1

4. *Notes* that the participating Party arrangements for authorizing the use of internationally transferred mitigation outcomes referred to in decision 2/CMA.3, annex, paragraph 4(c), [may] [shall] involve a single process [and/or result in [a consolidated] [an] authorization] that addresses, [inter alia and as appropriate, the information in paragraphs 8 and 9 below] [all elements referred to in decision 2/CMA.3, annex, paragraph 18];

5. *[Also] notes* that the participating Party arrangements for authorizing the use of internationally transferred mitigation outcomes referred to in decision 2/CMA.3, annex, paragraph 4(c), may involve a sequential process and[/or] result in separate authorizations that collectively address, [inter alia and as appropriate, the information in paragraphs 8 and 9 below] [all elements referred to in decision 2/CMA.3, annex, paragraph 18];

### Option 2

6. *Notes* that the authorization of cooperative approaches, entities and internationally transferred mitigation outcomes may be separate processes that may follow different timelines;

## Timing(SB60 draft text (12/6/2024), para7 timing)

### Option 1

7. *Clarifies* that internationally transferred mitigation outcomes can only be first transferred once they have been authorized in accordance with the arrangements described in paragraphs 4-5 and/or 6 above under an authorized cooperative approach [and upon the completion of the Article 6 technical expert review referred to in decision 2/CMA.3, annex, chapter V, and decision 18/CMA.1, annex, chapter VII];

**Option 2: {No text required}**

## Content (SB60 draft text (12/6/2024), para8 (ITMOs) and 9 (cooperative approach))

8. Decides that [each] participating Parties [Party] shall include in the authorizations [of the use of ITMOs from each cooperative approach] the following elements:

(a) [Unique identifier of the cooperative approach, as obtained from the centralized accounting and reporting platform[, where available]];

(b) [Name(s) of the first-transferring] Participating Party [or Parties] [and/or entities] [as per decision 2/CMA.3, annex, paragraph 20(b)];

(c) Date of authorization;

(d) [Definition of] [For the cooperative approach and if applicable, how the participating Party specifies] 'first transfer' [by the authorizing Party for the cooperative approach] [as (1) the authorization, (2) the issuance or (3) the use or cancellation of the mitigation outcome, as per decision 2/CMA.3, annex, paragraph 2];

(e) Arrangements for authorizing [using participating Parties or] entities, [as applicable];

(f) [Any applicable terms and conditions pertaining to changes to the authorization, as well as a description of the process for effecting and transparently communicating any changes];

(g) Arrangements for authorizing entities under the cooperative approach;

(h) [Information on how reversals [and leakage] are monitored and quantified, and when they occur, how they are addressed in full, including what methodological approaches are used to address reversals [and leakage] and how the responsibility for addressing reversals [and leakage] is assigned, the duration and frequency of monitoring for reversals [and leakage], and measures envisaged in case of failures in monitoring];

### Option 1

9. Encourages each participating Party to include, [at its discretion,] the following [elements] [information] in the authorization(s)[, as appropriate,] for each cooperative approach, as per decision 2/CMA.3, annex, paragraph 18(g–i):

#### {Information about the cooperative approach}

(a) Name and [parameters] [description] of the cooperative approach [as per decision 2/CMA.3, annex, paragraphs 18(g) and 20(b)];

(b) Type of carbon market instrument that will be used;

(c) Duration of the cooperative approach [as per decision 2/CMA.3, annex, paragraph 18(g)];

(d) Sector(s) [as per decision 2/CMA.3, annex, paragraph 20(b)];

(e) Vintage(s) [of the underlying mitigation outcome] [as per decisions 2/CMA.3, annex, paragraphs 20(b) and 23(j), and decision 6/CMA.4, annex I, paragraph 5(e)];

(f) [Activity(ies) and/or]Activity type(s) [as per decision 2/CMA.3, annex, paragraph 20(b)];

(g) [Regulatory framework,] procedures[,] and [certification] standards [and/or methodology(ies)] [applied in] [underpinning] the [implementation of the] cooperative approach];

(h) Metrics and [units of] [methods for its] measurement [or conversion and the greenhouse gases covered] [as per decision 2/CMA.3, annex, paragraph 22(c–d)];

(i) [Activity(ies) and/or]Activity type(s) [as per decision 2/CMA.3, annex, paragraph 20(b)];

(j) [Arrangements for change and revocation of authorization of the cooperative approach];

#### {Tracking arrangements}

(k) [Identification of the authorizing Party's] Registry [or registries involved in] [for the purpose of] tracking [that records internationally transferred mitigation outcomes] [internationally transferred mitigation outcomes] [as per decision 2/CMA.3, annex, chapter VI,] from the cooperative approach;

(l) [Identification of any other registries involved in the cooperative approach for the purposes of tracking internationally transferred mitigation outcome, mitigation outcomes and activities underpinning the cooperative approach, as applicable];

#### Scope and parameters of authorization

(m) Duration of authorization [as per decision 2/CMA.3, annex, paragraph 20(b)];

(n) [For the cooperative approach, the use(s) authorized by the participating Party towards achievement of nationally determined contributions and/or for other international mitigation purposes consistent with decision 2/CMA.3, annex, paragraph 1(d) and (f)];

(o) [For the cooperative approach, the name(s) of the authorized using participating Party or Parties or entity or entities, as applicable];

(p) [Authorized entities];

#### {Contributions for adaptation and overall mitigation in global emissions}

(q) [Contribution of resources for adaptation [referred to in decision 2/CMA.3, annex, chapter VII] [as per decision 2/CMA.3, annex, [paragraph 22(j) and chapter VII] [paragraph 37]]];

(r) [Contribution to overall mitigation in global emissions [referred to in decision 2/CMA.3, annex, chapter VII] as per decision 2/CMA.3, annex, [paragraph 22(k) and chapter VII] [paragraph 39]]];

#### {Other information}

(s) Other information relevant to the authorization and[or] cooperative approach, [as per decision 2/CMA.3] [as per decision 3/CMA.3, annex, paragraph 42];

(t) [Information on how participation in each cooperative approach and all cooperative approaches in which the Party participates combined contributes to the implementation of its NDC and long-term low-emission development strategy, if it has submitted one, and the long-term goals of the Paris Agreement];

(u) [Information on how the mitigation outcomes from each cooperative approach are shared between the participating Parties involved];

#### {Elements of the initial report related to corresponding adjustments}

(v) [Specification of the indicators to which corresponding adjustments will be applied];

(w) [The methods used for establishing the indicative trajectory, trajectories or budgets and the resulting trajectory, trajectories or budget for each relevant indicator, where applicable];

(x) [Information on how the method for applying corresponding adjustments ensures that the implementation of the cooperative approach(es) do(es) not lead to a net increase in emissions of participating Parties within and between NDC implementation periods and that corresponding adjustments are representative of and consistent with participating Parties' NDC implementation and achievement];

#### {Elements of the initial report related to environmental integrity}

(y) [Information on which methodological approaches are used for quantifying the mitigation outcomes derived from the cooperative approach];

(z) [Information on how uncertainties in the quantification of mitigation outcomes are taken into account];

(aa) [Information on how any baseline or reference levels have been established, including how it is ensured that the baseline or reference levels are conservative and below 'business as usual' emission projections, and information on what assumptions have been made, taking into account uncertainty];

(bb) [Information on how policies such as relevant laws, regulations or targets have been taken into account in establishing baselines or references levels];

(cc) [Information on how the cooperative approach facilitates the achievement of the long-term goals of the Paris Agreement and avoids locking in emission levels, technologies or practices that are inconsistent with achieving those goals];

(dd) [Information on how the risk of non-permanence is assessed under the cooperative approach and minimized across more than one NDC period, including the frequency and timing of risk assessments, the methodological approaches used, and what types of risks are considered];

(ee) [Information on how the risks of non-permanence are minimized across several NDC periods, including what measures have been taken to minimize risks and what time horizons have been considered];

(ff) [Information on how reversals are monitored and quantified, including what methodological approaches are used, the duration and frequency of monitoring for reversals, and measures envisaged in case of failures in monitoring];

#### Option 2: {No text required}

**Option 1** {*mandatory standardized form*}

10. *Requests* the secretariat, as the administrator of the centralized accounting and reporting platform, to develop and publish [one or more] [a] [standardized] and user-friendly [forms][template], as necessary, for the [arrangements] [information] outlined in [paragraph[s] 8 [and 9 above]], [for] [that] a participating Party shall use to provide the information [requested in] [required by] decision 2/CMA.3, annex, paragraph 18 [to support the consistency and transparency of information provided]]];

**Option 2:** {*voluntary standardized form*}

11. *Requests* the secretariat, as the administrator of the centralized accounting and reporting platform, to develop and publish [one or more] [a] voluntary, [standardized] and user-friendly [forms][template], as necessary, for the [arrangements] [information] outlined in paragraph[s] 8 [and 9 above], [for] [that] a participating Party may use at its discretion [to provide the information [requested in] [required by] decision 2/CMA.3, annex, paragraph 18 [to support the consistency and transparency of information provided]]];

**Option 3** {*no form*}

12. *Notes* that participating Parties may provide the information outlined in paragraph[s] 8 [and 9 above] in a format of their choosing;

**Option 4:** {*No text required*}

{*End of option*}

**Option 1: {no changes to authorization}**

13. *Decides* that there shall be no change to the authorization status of ITMOs.

**Option 2: {no changes to authorization after first transfer}**

14. *Decides* that any changes [and/or revocations] to an authorization [of a cooperative approach] [of the use of ITMOs] shall not apply to or affect internationally transferred mitigation outcomes that have already been first transferred;

**Option 3: {no changes to authorization after first transfer, unless mutually agreed}**

15. *Decides* that any changes [and/or revocations] to an authorization [of a cooperative approach] [of the use of ITMOs] shall not apply to or affect internationally transferred mitigation outcomes that have already been first transferred, unless otherwise agreed and made publicly available by the participating Parties in a cooperative approach;

16. *Decides* that if participating Parties agree to make changes to the authorization of [the use of] an internationally transferred mitigation outcome, each participating Party shall ensure the avoidance of double counting that could arise from such changes, consistent with Article 6, paragraph 2;

**Option 4 {changes to authorization do not affect first transferred ITMOs, unless otherwise publicly agreed or under extreme circumstances}**

17. *Decides* that any changes [and/or revocations] to an authorization [of a cooperative approach] [of the use of ITMOs] [should] [shall] not apply to or affect internationally transferred mitigation outcomes that have already been first transferred, [unless otherwise agreed and made publicly available by the participating Parties in a cooperative approach [or unless made by a participating Party under extreme circumstances]];

18. *Decides* that if participating Parties make changes to the authorization of [the use of] an internationally transferred mitigation outcome, each participating Party shall ensure the avoidance of double counting that could arise from such changes, consistent with Article 6, paragraph 2;

**Option 5 {changes to authorization do not affect first transferred ITMOs, unless otherwise publicly agreed or under previously agreed set of extreme circumstances}**

19. *Emphasizes* that any changes to an authorization of the use of internationally transferred mitigation outcomes should not apply to or affect mitigation outcomes covered by that authorization that have already been first transferred [**Option 5A:** , subject to any applicable terms and provisions in the authorization that specify the circumstances for such changes and the process for managing them, taking into account other participating Parties and/or authorized entities in the cooperative approach, and, where relevant, limiting any revocations of first transfers to extreme circumstances [such as those involving, inter alia, violations of domestic statutes, or national security, or inconsistencies with the eleventh preambular paragraph of the Paris Agreement, or with this guidance and relevant decisions of the CMA]] [**Option 5B:**, unless otherwise agreed and made publicly available by the participating Parties in a cooperative approach or unless made by a participating Party under extreme circumstances];

**Option 6 {changes to authorization at any time}**

20. *Notes* that participating Parties may change and/or revoke the authorization of ITMOs at any time;

**Option 7 {scope and process for changes deferred to review}**

21. *Requests* the Subsidiary Body for Scientific and Technological Advice, as part of the review of the guidance to be initiated by the Conference of the Parties serving as the meeting of the Parties to the Paris Agreement at its tenth session (2028),<sup>2</sup> to continue considering the potential scope of changes to the authorization of internationally transferred mitigation outcomes towards use(s) and a process for managing them that avoids double counting;

**Option 8: {no text required}**



**Option 1 {User-friendly template published by the secretariat in the international registry}**

22. *Requests* the secretariat[, in consultation with registry system administrators through the voluntary forum of Article 6 registry system administrators and technical experts of participating Parties,] to develop the [functionalities for participating Parties to publish copies of their authorization, or to utilize at their discretion the voluntary, standardized and user-friendly template referred to in paragraph [10][11] above to provide information on their authorization referred to in paragraph[s] 8 [and 9 above]D above, as appropriate, on] [standardized data structure for internationally transferred mitigation outcome authorizations, implement this structure in] the international registry[, and include the [specification of the data structure] [specified functionalities] in the standards and recommended practices for recording of data and information related to internationally transferred mitigation outcomes referred to in decision 6/CMA.4, paragraph 32, for use by registries that connect to the international registry[, consistently with this guidance and future relevant decisions of the Conference of the Parties serving as the meeting of the Parties to the Paris Agreement, for review by the Subsidiary Body for Scientific and Technological Advice at its sixty-first session];

**Option 2 {Public repository in the CARP with no specified format}**

23. *Clarifies* that, as per decision 2/CMA.3, annex, paragraph 35, the centralized accounting and reporting platform will provide a public repository for Parties' statements and/or copies of authorization, including any changes or updates made to their authorization;

**Option 3 {Notification to all participating Parties and publication by the registry of the authorizing Party}**

24. *Clarifies* that a copy of the authorization(s) of the use of ITMOs, as well as any changes thereto, is to be included with the information on the authorization and any changes to the earlier authorization in the regular information as per decision 2/CMA.3, annex, paragraph 21(c); notified to authorized participating Parties and/or entities; published on the registry of the authorizing Party and delivered to all registries involved in the same cooperative approach, and that the delivery should be organized in a way that it is completed as soon as practicable to enable its transparent and timely application;

**Option 4: {No text required}**

# SBSTA60 (Version 12<sup>th</sup> Jun, 2024)

## B. Content of the authorization

8. *Decides* that [each] participating Parties [Party] shall include in the authorizations [of the use of ITMOs from each cooperative approach] the following elements:

- (a) [Unique identifier of the cooperative approach, as obtained from the centralized accounting and reporting platform[, where available]];
- (b) [Name(s) of the first-transferring] Participating Party [or Parties] [and/or entities] [as per decision 2/CMA.3, annex, paragraph 20(b)];
- (c) Date of authorization;
- (d) [Definition of] [For the cooperative approach and if applicable, how the participating Party specifies] ‘first transfer’ [by the authorizing Party for the cooperative approach] [as (1) the authorization, (2) the issuance or (3) the use or cancellation of the mitigation outcome, as per decision 2/CMA.3, annex, paragraph 2];
- (e) Arrangements for authorizing [using participating Parties or] entities, [as applicable];
- (f) [Any applicable terms and conditions pertaining to changes to the authorization, as well as a description of the process for effecting and transparently communicating any changes];
- (g) Arrangements for authorizing entities under the cooperative approach;
- (h) [Information on how reversals [and leakage] are monitored and quantified, and when they occur, how they are addressed in full, including what methodological approaches are used to address reversals [and leakage] and how the responsibility for addressing reversals [and leakage] is assigned, the duration and frequency of monitoring for reversals [and leakage], and measures envisaged in case of failures in monitoring];

# SBSTA60 (Version 12<sup>th</sup> Jun, 2024)

## Option1

9. *Encourages* each participating Party to include, [at its discretion,] the following [elements] [information] in the authorization(s)[, as appropriate,] for each cooperative approach, as per decision 2/CMA.3, annex, paragraph 18(g–i):

### **{Information about the cooperative approach}**

- (a) Name and [parameters] [description] of the cooperative approach
- (b) Type of carbon market instrument that will be used;
- (c) Duration of the cooperative approach;
- (d) Sector(s)
- (e) Vintage(s) [of the underlying mitigation outcome] ;
- (f) [Activity(ies) and/or]Activity type(s) ;
- (g) [Regulatory framework,] procedures[,] and [certification] standards [and/or methodology(ies)] [applied in] [underpinning] the [implementation of the] cooperative approach];
- (h) Metrics and [units of] [methods for its] measurement [or conversion and the greenhouse gases covered] ;
- (i) [Activity(ies) and/or]Activity type(s) ;
- (j) [Arrangements for change and revocation of authorization of the cooperative approach];
- (k) [Identification of the authorizing Party’s] Registry [or registries involved in] [for the purpose of] tracking [that records internationally transferred mitigation outcomes] [internationally transferred mitigation outcomes] from the cooperative approach;
- (l) [Identification of any other registries involved in the cooperative approach for the purposes of tracking internationally transferred mitigation outcome, mitigation outcomes and activities underpinning the cooperative approach, as applicable];

# SBSTA60 (Version 12<sup>th</sup> Jun, 2024)

(m) Duration of authorization;

(n) [For the cooperative approach, the use(s) authorized by the participating Party towards achievement of nationally determined contributions and/or for other international mitigation purposes consistent with decision 2/CMA.3, annex, paragraph 1(d) and (f);]

(o) [For the cooperative approach, the name(s) of the authorized using participating Party or Parties or entity or entities, as applicable;]

(p) [Authorized entities;]

(q) [Contribution of resources for adaptation;

(r) [Contribution to overall mitigation in global emissions;

## **{Other information}**

(s) Other information relevant to the authorization and[/or] cooperative approach, ;

(t) [Information on how participation in each cooperative approach and all cooperative approaches in which the Party participates combined contributes to the implementation of its NDC and long-term low-emission development strategy, if it has submitted one, and the long-term goals of the Paris Agreement];

(u) [Information on how the mitigation outcomes from each cooperative approach are shared between the participating Parties involved];

## ***{Elements of the initial report related to corresponding adjustments}***

(v) [Specification of the indicators to which corresponding adjustments will be applied];

(w) [The methods used for establishing the indicative trajectory, trajectories or budgets and the resulting trajectory, trajectories or budget for each relevant indicator, where applicable];

# SBSTA60 (Version 12<sup>th</sup> Jun, 2024)

x) [Information on how the method for applying corresponding adjustments ensures that the implementation of the cooperative approach(es) do(es) not lead to a net increase in emissions of participating Parties within and between NDC implementation periods and that corresponding adjustments are representative of and consistent with participating Parties' NDC implementation and achievement];

## ***{Elements of the initial report related to environmental integrity}***

(y) [Information on which methodological approaches are used for quantifying the mitigation outcomes derived from the cooperative approach];

(z) [Information on how uncertainties in the quantification of mitigation outcomes are taken into account];

(aa) [Information on how any baseline or reference levels have been established, including how it is ensured that the baseline or reference levels are conservative and below 'business as usual' emission projections, and information on what assumptions have been made, taking into account uncertainty];

(bb) [Information on how policies such as relevant laws, regulations or targets have been taken into account in establishing baselines or references levels];

(cc) [Information on how the cooperative approach facilitates the achievement of the long-term goals of the Paris Agreement and avoids locking in emission levels, technologies or practices that are inconsistent with achieving those goals];

(dd) [Information on how the risk of non-permanence is assessed under the cooperative approach and minimized across more than one NDC period, including the frequency and timing of risk assessments, the methodological approaches used, and what types of risks are considered];

(ee) [Information on how the risks of non-permanence are minimized across several NDC periods, including what measures have been taken to minimize risks and what time horizons have been considered];

(ff) [Information on how reversals are monitored and quantified, including what methodological approaches are used, the duration and frequency of monitoring for reversals, and measures envisaged in case of failures in monitoring];